

Scambiatore tipo SS10 Serie Aria-Olio Heat exchanger series SS10 Air-Oil version



CARATTERISTICHE TECNICHE DEL GRUPPO DI VENTILAZIONE TECHNICAL FEATURES

Tipologia Type	Frequenza Frequency Hz	Tensione Voltage V	N° Giri/min RPM	Potenza Power kW	Diam. Ventola Ø FAN (mm)	dB (A)	L (mm)	Q air (m³/h)	Cap. (lt)	Peso Weight (kg)	IP
01	50/60	230	2600/2980	0.023/0.026	170	50	122	500	0.28	6	44
03	50/60	380	1470/1750	0.032/0.027	170	45	122	500	0.28	6	44
12	DC	12	4101	0.076	167	71	167	569	0.28	5	68
24	DC	24	4101	0.076	167	71	167	560	0.28	5	68

Portata olio consigliata da 5 a 40 (lt/min)
Suggested oil flow from 5 to 40 (lt/min)

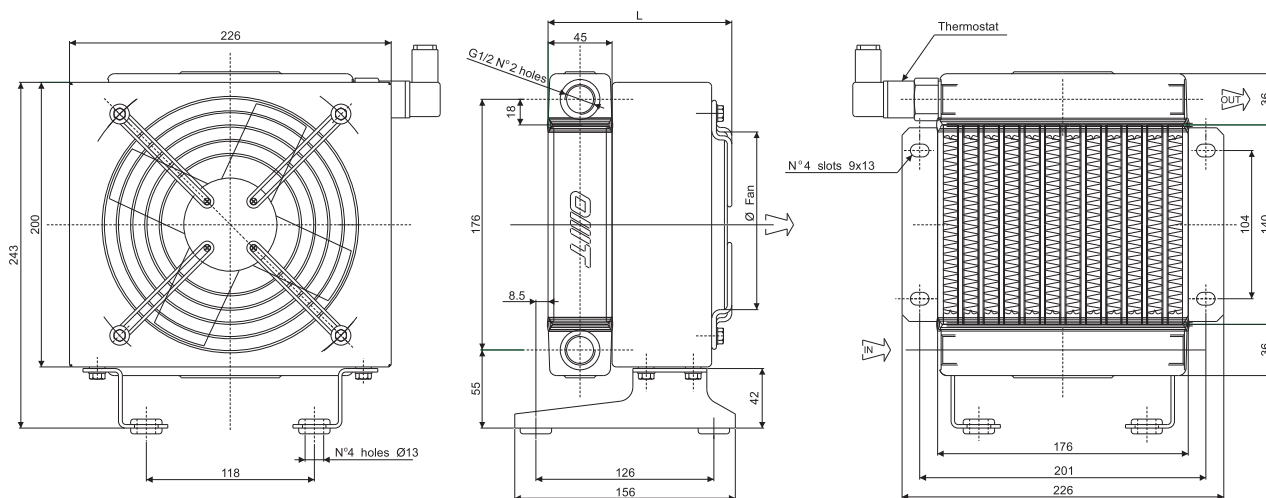

Coefficiente di correzione Correction factor

CST	10	15	20	32	40	50	60	80	100	200
F	0.51	0.66	0.76	1	1.22	1.4	1.6	1.9	2.1	3.4

Diagramma di rendimento Performance diagram

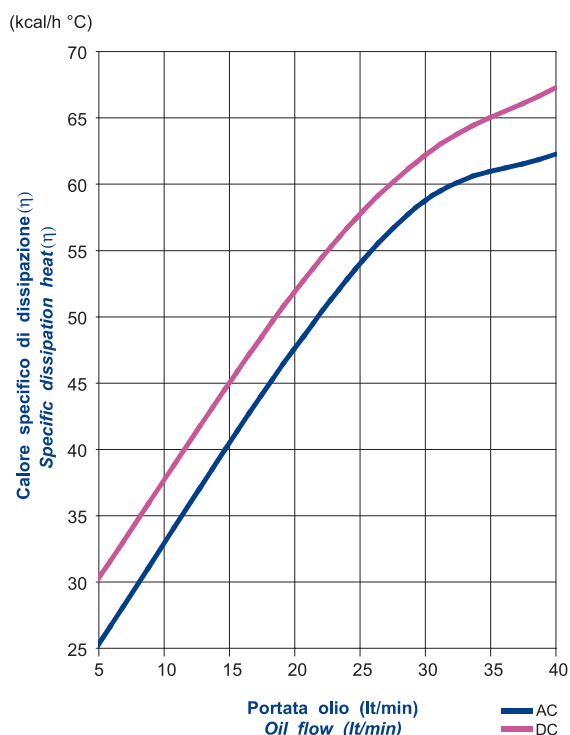

Diagramma perdite di carico (32 cst) Pressure drop diagram (32 cst)

