

## SNP1IN/



### SKUPINA 1

#### Technické dáta



|                                     |       | Veľkosť |      |      |       |       |       |       |       |       |
|-------------------------------------|-------|---------|------|------|-------|-------|-------|-------|-------|-------|
|                                     |       | 1,2     | 1,7  | 2,2  | 2,6   | 3,2   | 3,8   | 4,3   | 6,0   | 7,8   |
| Objem                               | ccm   | 1,18    | 1,57 | 2,09 | 2,62  | 3,14  | 3,66  | 4,19  | 5,89  | 7,59  |
| Maximálny tlak                      | bar   | 270     | 270  | 270  | 270   | 270   | 270   | 270   | 210   | 170   |
| Menovitý tlak                       |       | 250     | 250  | 250  | 250   | 250   | 250   | 250   | 190   | 150   |
| Maximálne otáčky                    | min-1 | 4000    | 4000 | 4000 | 4000  | 4000  | 4000  | 3000  | 3000  | 3000  |
| Hmotnosť                            | kg    | 1,02    | 1,05 | 1,09 | 1,11  | 1,14  | 1,18  | 1,20  | 1,30  | 1,39  |
| Prietok pri 1400 ot/min             | l/min | 1,49    | 1,98 | 2,63 | 3,3   | 3,96  | 4,61  | 5,28  | 7,42  | 9,56  |
| Teoretický prietok pri max otáčkach | l/min | 4,72    | 6,28 | 8,36 | 10,48 | 12,56 | 14,64 | 16,76 | 17,67 | 22,77 |

#### Montážna príruha

#### Hriadel'

|    |   |                         |    |  |            |
|----|---|-------------------------|----|--|------------|
| 01 |  | pilot Ø 25,4 + 4 otvory | BA |  | Kužel' 1:8 |
|----|---|-------------------------|----|--|------------|

#### Porty

| Sanie |   |         | Výtlak |  |         |
|-------|---|---------|--------|--|---------|
| F3    |  | 3/8 GAS | F3     |  | 3/8 GAS |

#### Rozmery

|   | 1,2   | 1,7   | 2,2   | 2,6    | 3,2    | 3,8    | 4,3    | 6,0    | 7,8    |
|---|-------|-------|-------|--------|--------|--------|--------|--------|--------|
| B | 95,50 | 97,00 | 99,00 | 101,00 | 103,00 | 105,00 | 107,00 | 113,50 | 120,00 |

01BA

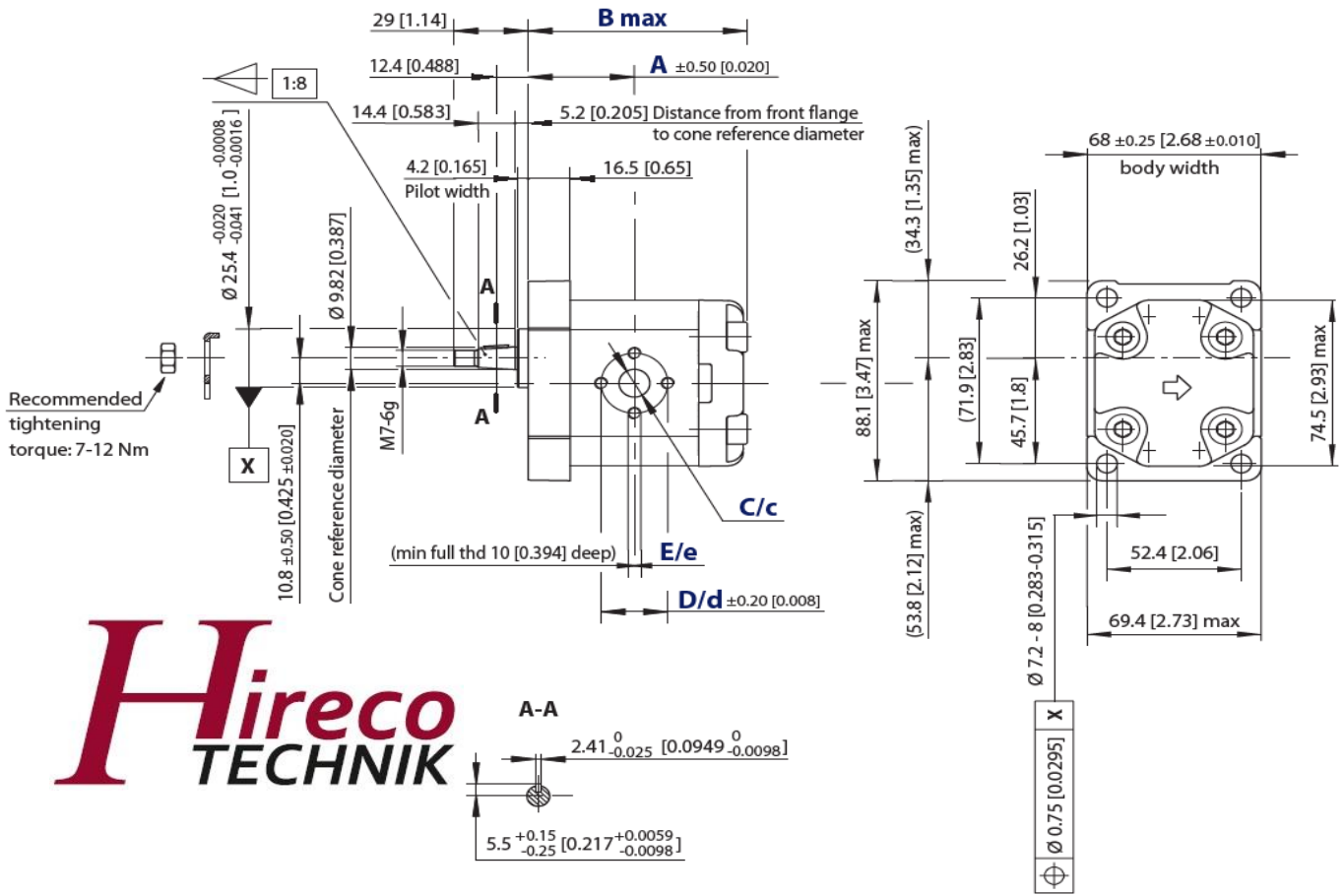

Poistný ventil

|     |   |                       |             |
|-----|---|-----------------------|-------------|
| VGD | V | Poistný ventil        |             |
|     | G | Nastavovacia rýchlosť | 1500 ot/min |
|     | D | Prednastavený tlak    | 25 bar      |

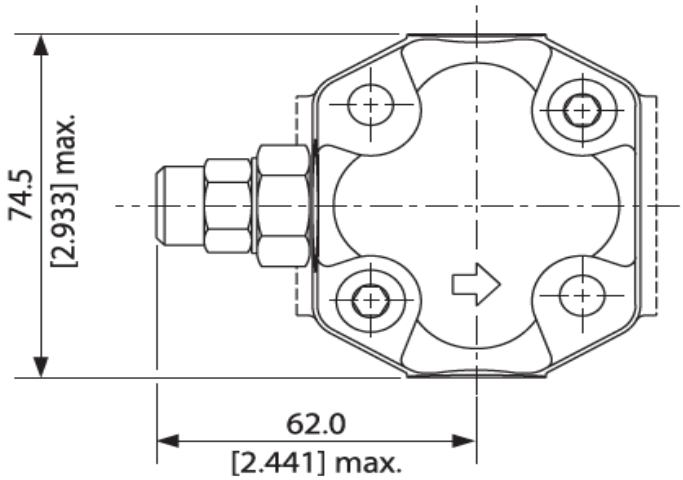
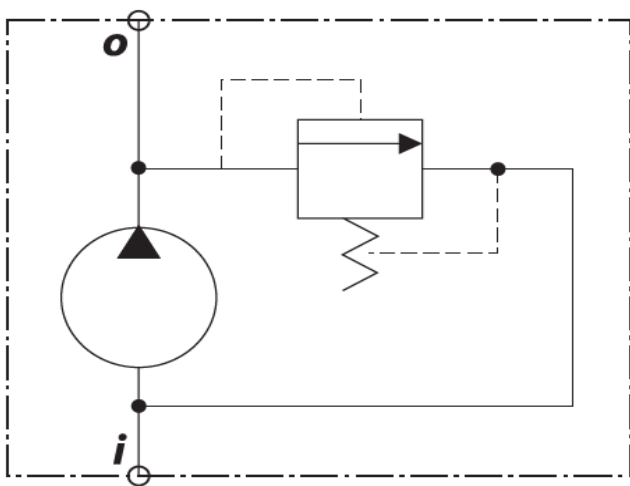

i = inlet  
o = outlet