

### ANELLI AMMORTIZZANTI / DAMPING RINGS

tipo / series **A**

Costituiti da due anelli con interposta gomma vulcanizzata, vengono applicati tra lanterna e coperchio del serbatoio per smorzare le vibrazioni generate dalla trasmissione. Resistenti agli olii minerali possono lavorare fino ad una temperatura di + 80°C, riducendo la rumorosità del sistema di circa 3÷5 decibel.

These articles are made of two rings moulded into vulcanized rubber. Interposed between the bellhousing and the tank cover, they diminish the noise created by the power transmission by approx. 3÷5 dB. The employed rubber is mineral oil resistant, max. working temperature is 80°C.



Tabella / Table 22

Codice Part number	Dimensioni (mm) / Dimensions (mm)					
	A	B	C	D	E	F
<b>A-200</b>	146	200	165	15	43	M10
<b>A-250</b>	191	250	215	18	48	M12
<b>A-300</b>	238	300	265	18	53	M12
<b>A-350</b>	261	350	300	24	61,5	M16
<b>A-400</b>	311	400	350	24	69	M16

### SUPPORTO MOTORE A PIEDINO / FOOT FLANGES

tipo / series **P**

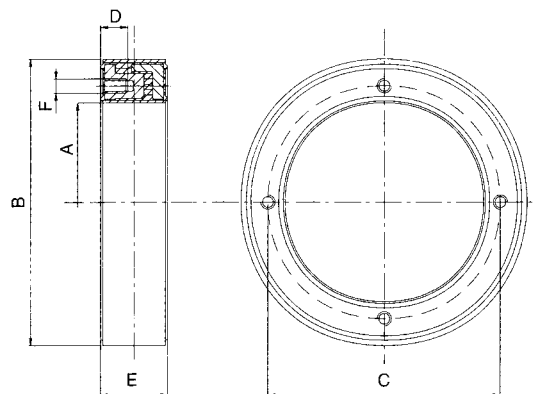
Costruiti in lega di alluminio ad elevata resistenza meccanica vengono utilizzati quali supporti per lanterne con flangiatura normalizzata B5 sino ad un diametro esterno del motore di 350 mm. Da un Ø 400 est. del motore i piedini vengono costruiti in ferro.

Manufactured of high resistance aluminium alloy, these flanges are used to support our bellhousings with standard B5 flange up to an external diameter of the motor of Ø 350 mm. From Ø 400 upwards these foot flanges are made of steel.



Tabella / Table 23

Codice Part number	Dimensioni (mm) / Dimensions (mm)														
	A	B	C	D	E	F	G	I	N	O	P	Q	R	T	V
<b>P160</b>	165	135	80	100	45	10	45	98	80	111	130	10	9	35	9
<b>P200</b>	202	168	103	127	54	19	54	123	100	140	165	22	11,5	42,5	9
<b>P250</b>	252	220	130	155	105	25	25	150	125	180	215	25	13	92,5	11
<b>P300</b>	302	265	160	190	115	25	50	175	150	240	265	25	13	100	13
<b>P350</b>	362	310	250	286	183	30	73	205	175	256	300	30	18	165	15
<b>P400</b>	410	360	520	570	350	15	205	260	175	301	350	15	18	325	18
<b>P450</b>	460	400	590	640	390	15	235	295	200	351	400	15	18	365	18
<b>P550</b>	560	500	690	740	470	15	255	350	250	450	500	15	18	445	18

### GUARNIZIONI / GASKETS

tipo / series **GL**

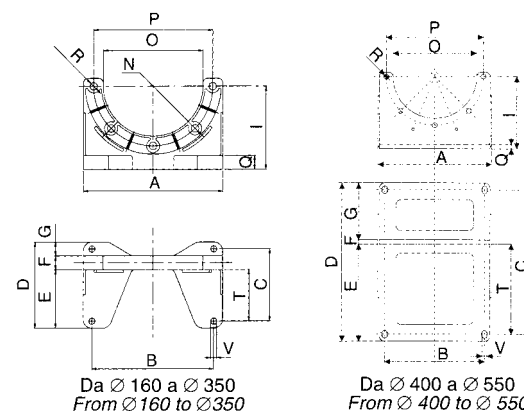
Guarnizioni in guarnital per lanterne. Tali guarnizioni vengono poste tra lanterne e serbatoi quale elemento di tenuta.

Gaskets for bellhousings, made of GUARNITAL. They are interposed between bellhousing and the oil tank.

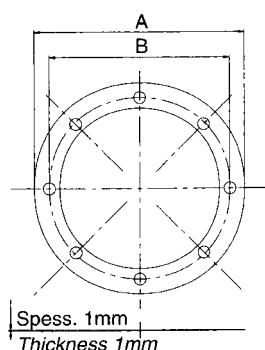

Codice Part number	Dimensioni (mm) Dimensions (mm)	
	A	B
<b>GL 140</b>	140	115
<b>GL 160</b>	160	130
<b>GL 200</b>	200	165
<b>GL 250</b>	250	215
<b>GL 300</b>	300	265
<b>GL 350</b>	350	300
<b>GL 400</b>	400	350

### GUARNIZIONI / GASKETS

tipo / series **GP**

Guarnizioni in guarnital per pompe ad ingranaggi. Tali guarnizioni vengono poste tra pompa e lanterna quale elemento di tenuta.

Gaskets for gear pumps, made of GUARNITAL. They are interposed between bellhousing and the pump.

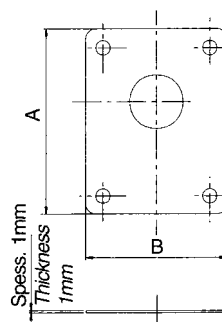

Codice Part number	Dimensioni (mm) Dimensions (mm)	
	A	B
<b>GP 05</b>	82	50
<b>GP 1</b>	90	69
<b>GP 05-1M</b>	90	69
<b>GP 2</b>	118	86
<b>GP ZF</b>	121	91
<b>GP 3</b>	170	120
<b>GP 35</b>	180	158
<b>GP 4</b>	230	175